

# STEVE'S AND SONS

203 Humble Ave.  
San Antonio, TX 78225

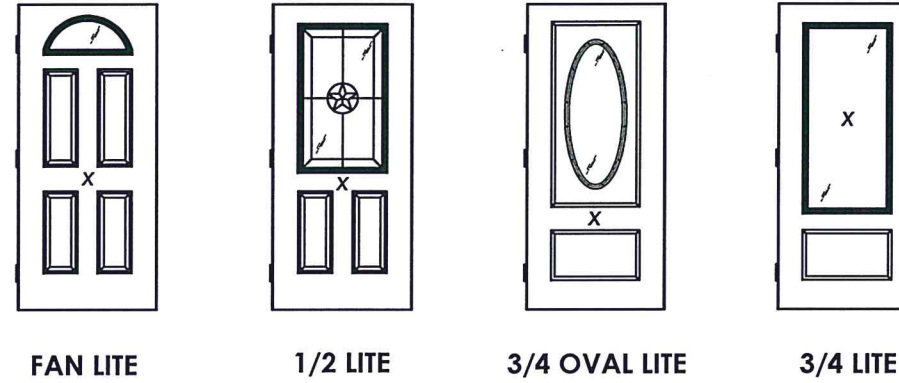

## GLAZED FIBERGLASS DOOR DOUBLE

INSWING/OUTSWING  
"NON-IMPACT"

### RELIANT DECORATIVE COLLECTION

June 6, 2022  
 Documents Prepared By: Lyndon F. Schmidt  
 P.E. No. 43409  
 No. 43409  
 F. SCHMIDT  
 LICENSE  
 STATE OF FLORIDA  
 PROFESSIONAL ENGINEER  
 BUILDING CONSULTANTS, INC.  
 P.O. Box 230, Valrico, FL 33595  
 Phone No.: 813.659.9197  
 FBPE Registry No. 9813

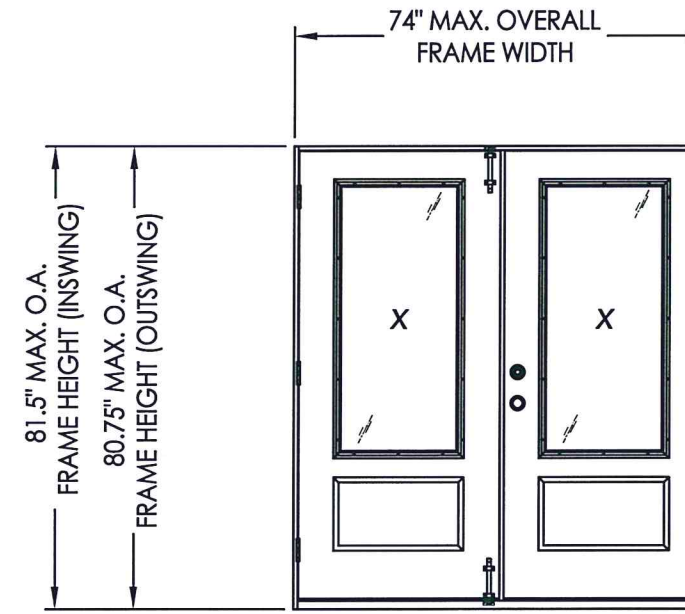

#### GENERAL NOTES

1. This product has been evaluated and is in compliance with the 7th Edition (2020) Florida Building Code (FBC) structural requirements excluding the "High Velocity Hurricane Zone" (HVHZ).
2. Product anchors shall be as listed and spaced as shown on details. Anchor embedment to base material shall be beyond wall dressing or stucco.
3. When used in areas requiring wind borne debris protection this product is required to be protected with an impact resistant covering that complies with FBC Sections 1609.1.2 & R301.2.1.2 of the FBC.
4. For 2x stud framing construction, anchoring of these units shall be the same as that shown for 2x buck masonry construction.
5. Site conditions that deviate from the details of this drawing require further engineering analysis by a licensed engineer or registered architect.

#### TABLE OF CONTENTS

SHEET #	DESCRIPTION	SHEET #	
1	Typical Elevations, Design Pressures & General Notes	6	Horizontal & Vertical Cross Sections (1X Buck)
2	Door Panel Details	7	Horizontal & Vertical Cross Sections (Direct to Masonry)
3	Panel Options	8	Vertical Cross Sections
4	Elevations	9	Buck & Frame Anchoring & Hardware Details
5	Horizontal & Vertical Cross Sections (2X Buck)	10	Bill of Materials & Components

CONFIGURATION	MAX. FRAME DIMENSION	SURFACE BOLTS REQUIRED	DESIGN PRESSURE (PSF) INSWING		DESIGN PRESSURE (PSF) OUTSWING	
			POSITIVE	NEGATIVE	POSITIVE	NEGATIVE
XX	74.0" x 81.5"	NO	+20.0	-20.0	+30.0	-30.0
		YES	+25.0	-30.0	+35.0	-35.0

PRODUCT: STEVE'S & SONS FIBERGLASS DOOR	
PART OR ASSEMBLY: TYPICAL ELEVATION, DESIGN PRESSURES & GENERAL NOTES	
NO.	DATE
BY	REVISIONS
DATE: 4/26/22	
SCALE: N.T.S.	
DWG. BY: RW	
CHK. BY: LFS	
DRAWING NO.: FL-41477.2	
SHEET 1 OF 10	

Z:\Clients\Steves and Sons - Permanent\A - Florida Product Approvals\FL-41477 RELIANT SERIES\C - Drawings\FL-41477 (2020)\FL-41477.2.dwg

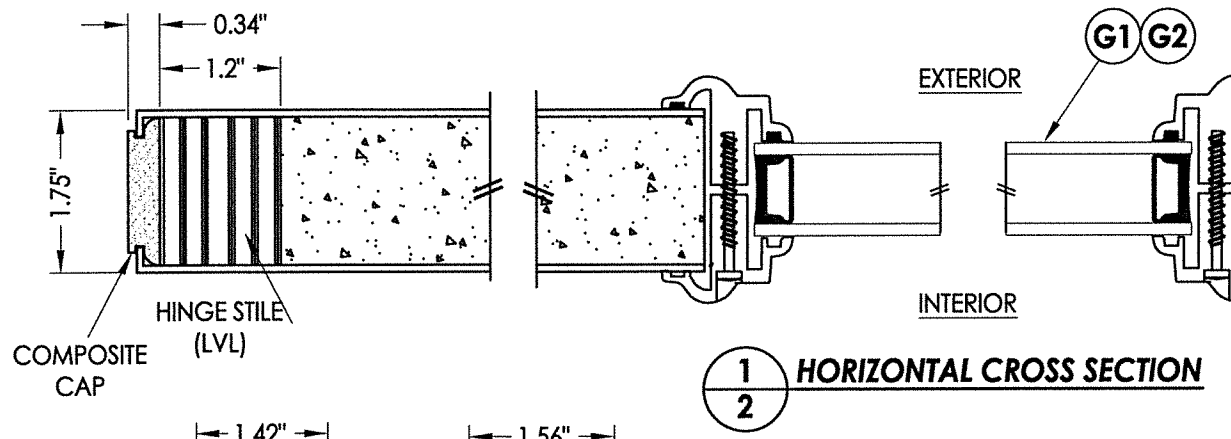

**1**  
**2** **HORIZONTAL CROSS SECTION**

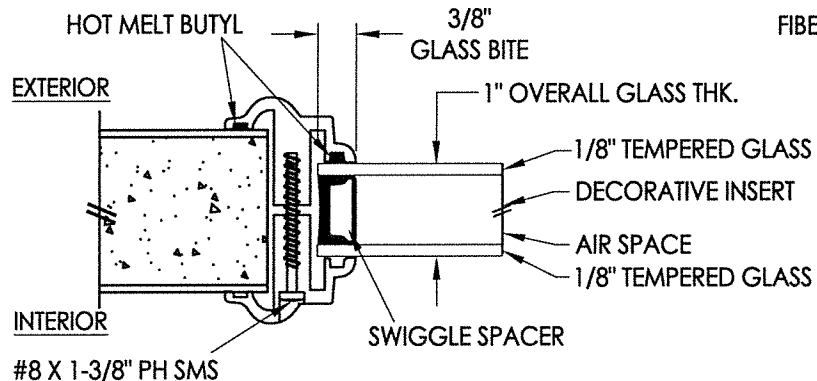
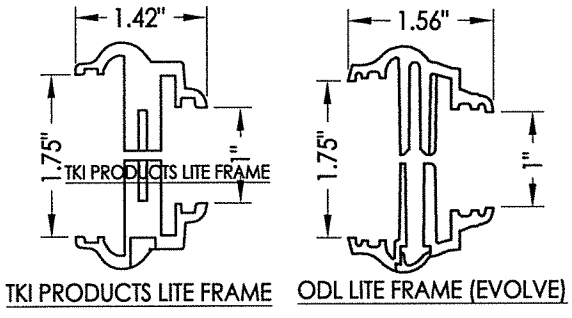

**G1** **GLAZING DETAIL**  
TKI PRODUCTS LITE FRAME

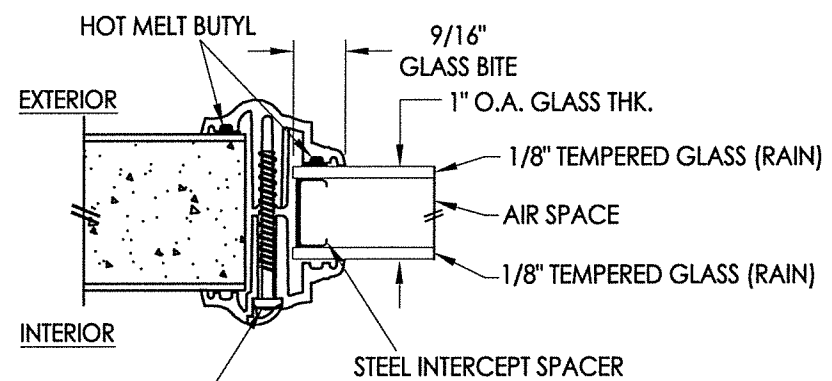

**G2** **GLAZING DETAIL**  
ODL LITE FRAME (EVOLVE)

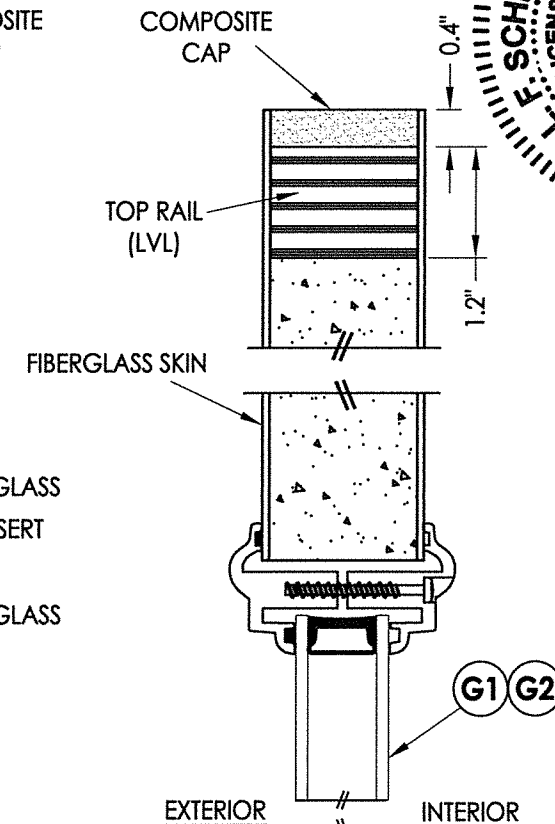

**2**  
**2** **VERTICAL CROSS SECTION**

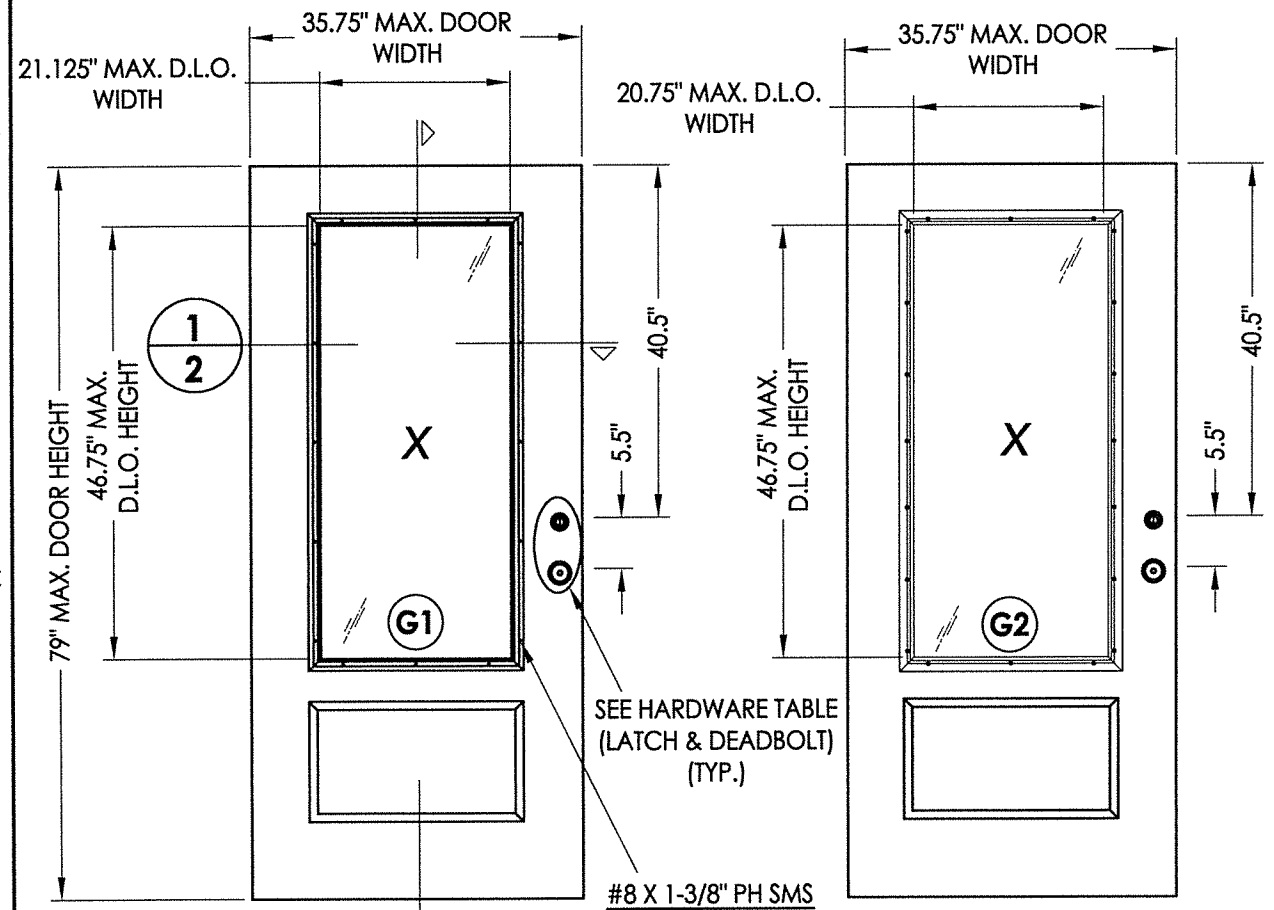

**40** **FIBERGLASS DOOR PANEL**  
TKI PRODUCTS LITE FRAME

**40** **FIBERGLASS DOOR PANEL**  
ODL LITE FRAME (EVOLVE)

#8 X 1-3/8\"/>

HARDWARE TABLE		
MANUFACTURER	MODEL	
KWIKSET	LATCH:	SIGNATURE SERIES
	DEADBOLT:	SIGNATURE SERIES (980)
SCHLAGE	LATCH:	F51
	DEADBOLT:	B60N
ROCKWELL	LATCH:	PREMIUM HANDLESET
	DEADBOLT:	PREMIUM DEADBOLT

FIBERGLASS DOOR SKIN: MIN. 0.07\"/>

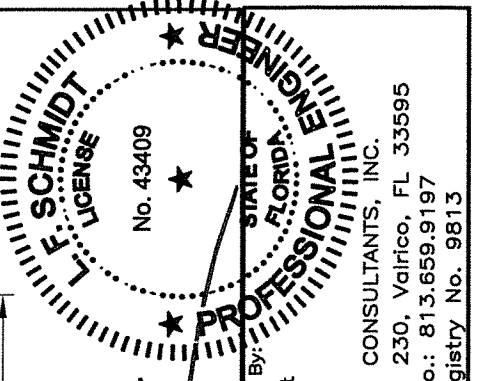

June 6, 2022

Documents Prepared By:  
Lyndon F. Schmidt  
P.E. No. 43409

**RW** BUILDING CONSULTANTS, INC.  
P.O. Box 230, Valrico, FL 33595  
Phone No.: 813.659.9197  
FBPE Registry No. 9813

PRODUCT:	STEVES & SONS FIBERGLASS DOOR
PART OR ASSEMBLY:	DOOR PANEL DETAILS

NO.	DATE	BY	REVISIONS

DATE:	4/26/22
SCALE:	N.T.S.
DWG. BY:	RW
CHK. BY:	LFS
DRAWING NO.:	FL-41477.2
SHEET	2 OF 10

© 2022 R.W. BUILDING CONSULTANTS INC.

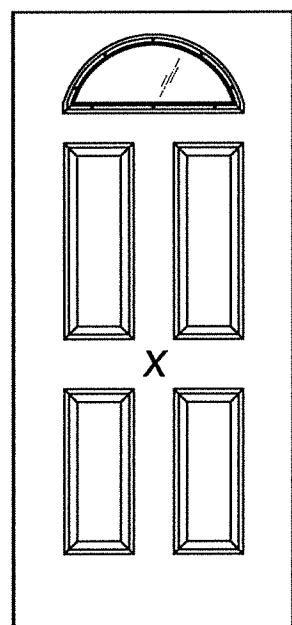

FAN LITE

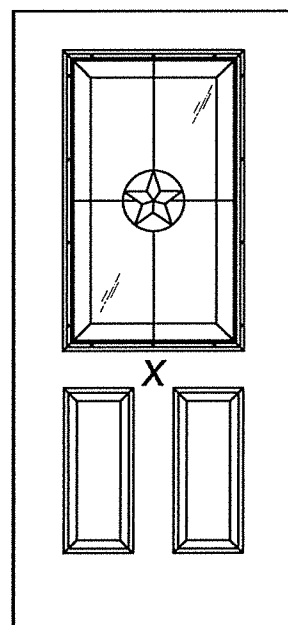

1/2 LITE

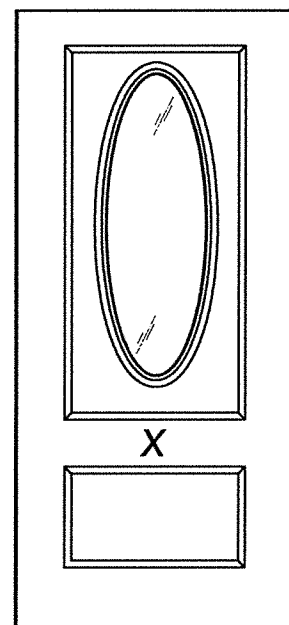

3/4 OVAL LITE

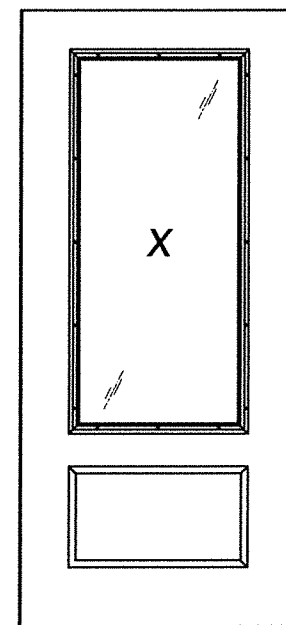

3/4 LITE

**RELIANT DECORATIVE COLLECTION**

DATE: 4/26/22  
 SCALE: N.T.S.  
 DWG. BY: RW  
 CHK. BY: LFS  
 DRAWING NO.: FL-41477.2  
 SHEET 3 OF 10

NO.	DATE	BY	REVISIONS

PRODUCT: STEVES & SONS  
FIBERGLASS DOOR  
 PART OR ASSEMBLY: PANEL OPTIONS

June 6, 2022  
 Documents Prepared By:  
 Lyndon F. Schmidt  
 P.E. No. 43409  
  
 RW BUILDING CONSULTANTS, INC.  
 P.O. Box 230, Valrico, FL 33595  
 Phone No.: 813.659.9197  
 FBPE Registry No. 9813

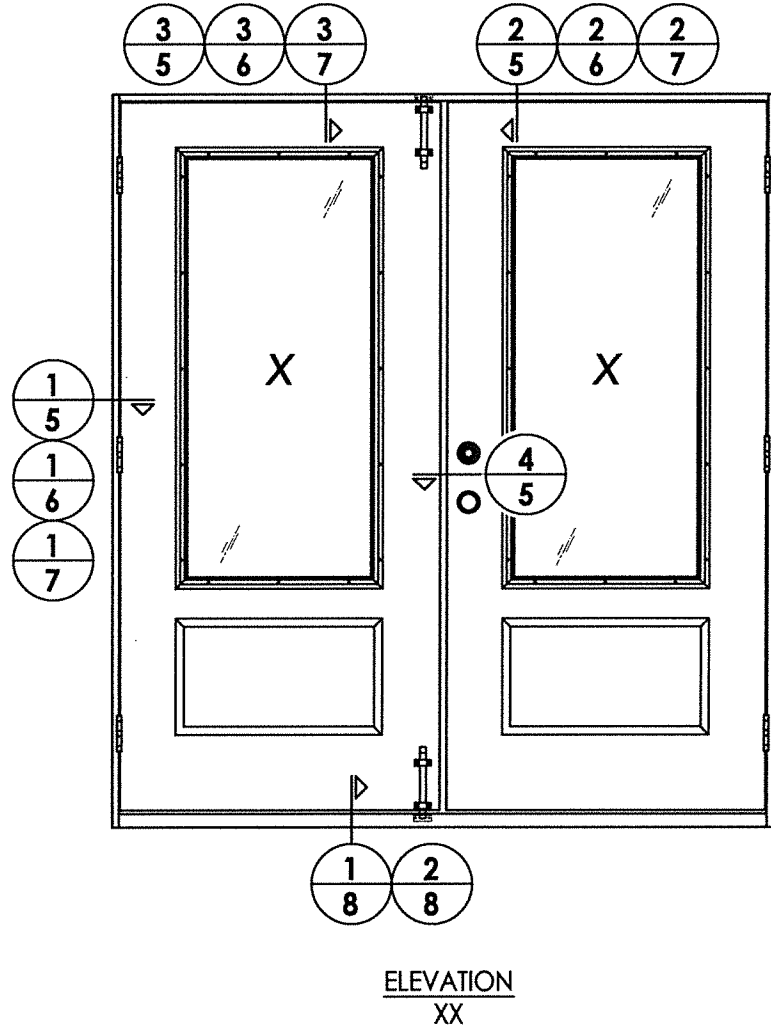

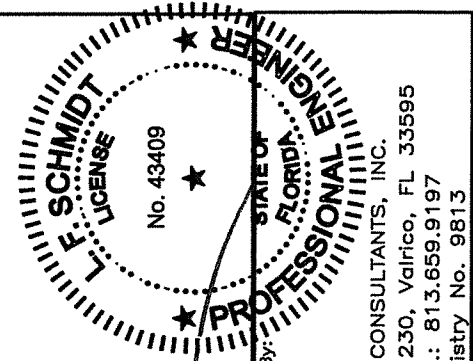
  
 June 6, 2022  
 Documents Prepared By:  
 Lyndon F. Schmidt  
 P.E. No. 43409  
*LFS*  
 R.W.  
 BUILDING CONSULTANTS, INC.  
 P.O. Box 230, Vairico, FL 33595  
 Phone No.: 813.659.9197  
 FBPE Registry No. 9813

PRODUCT:		STEVE'S & SONS FIBERGLASS DOOR	
PART OR ASSEMBLY:		ELEVATIONS	
DATE:	4/26/22	NO.	BY
SCALE:	N.T.S.	DATE	REVISIONS
DWG. BY:	RW		
CHK. BY:	LFS		
DRAWING NO.:	FL-41477.2		
SHEET	4	OF	10

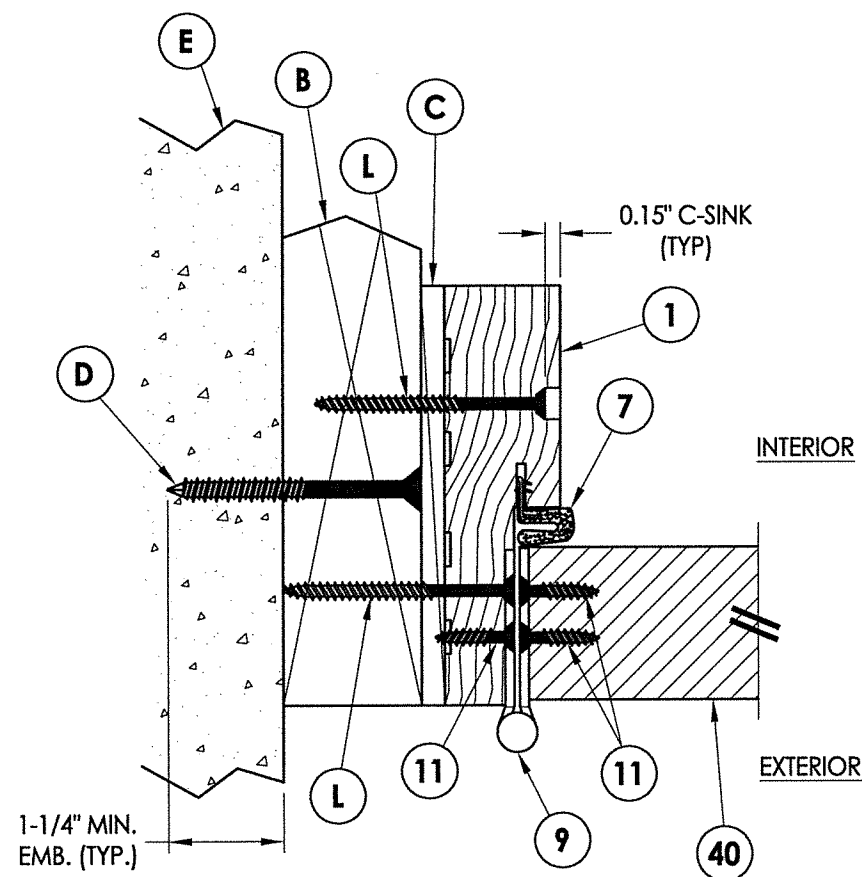

**1 HORIZONTAL CROSS SECTION**  
**5** Shown w/ 2X Buck  
 Outswing shown (Inswing similar)

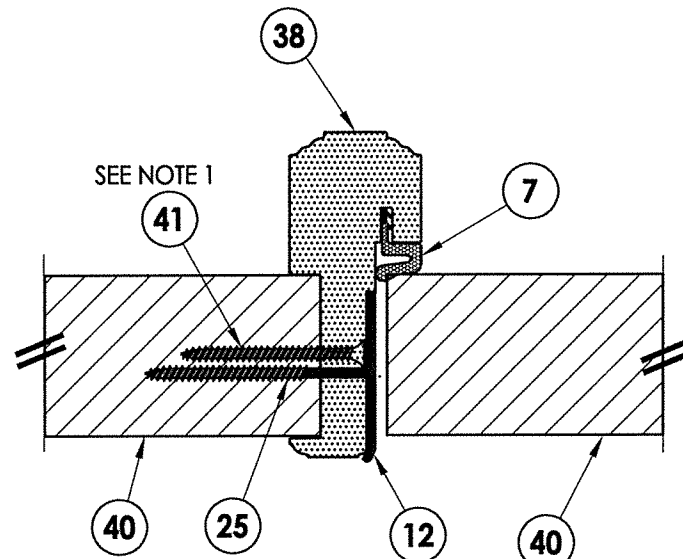

**4 HORIZONTAL CROSS SECTION**  
**5** Outswing shown (Inswing similar)

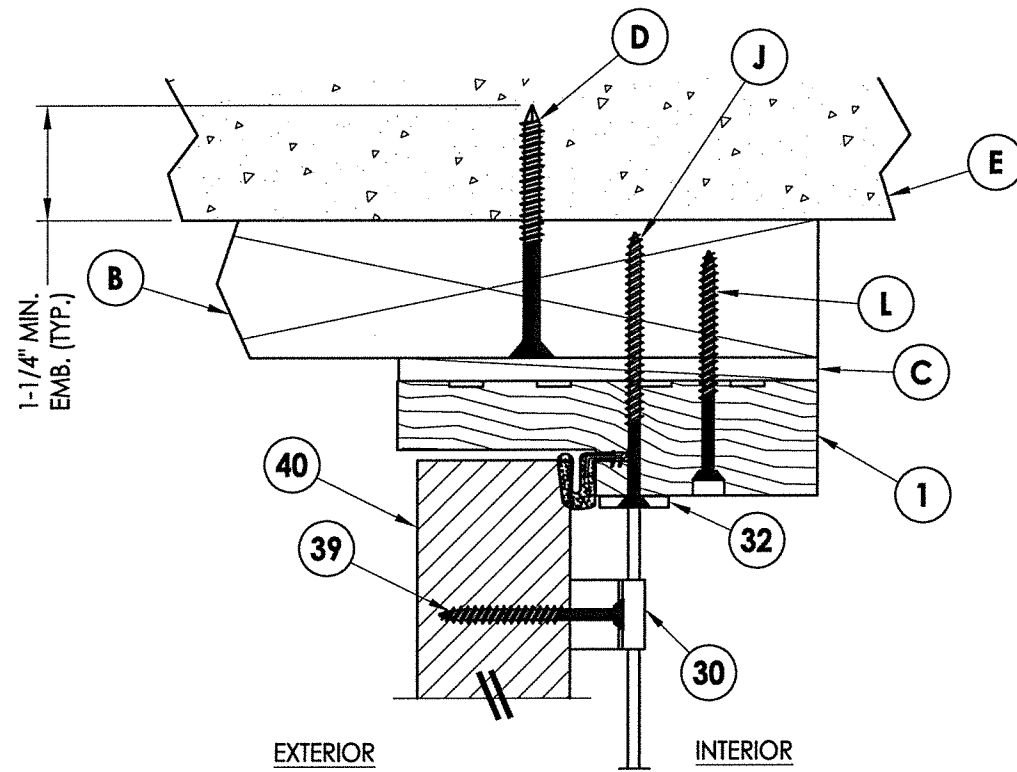

**2 VERTICAL CROSS SECTION**  
**5** Shown w/ 2X Buck  
 Outswing shown

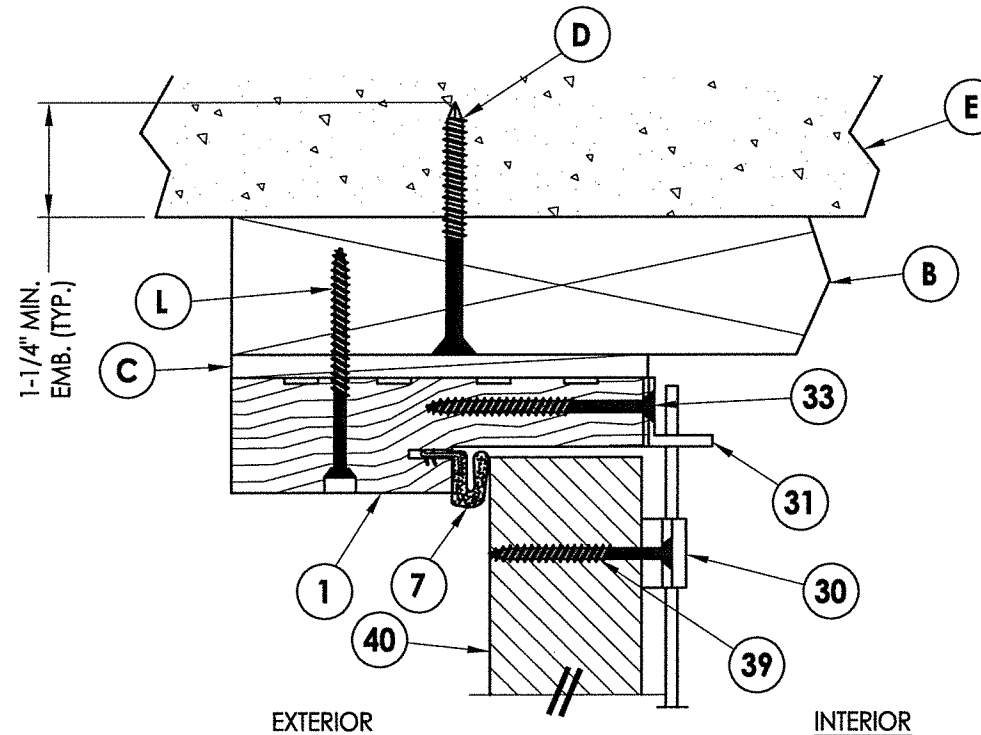

**3 VERTICAL CROSS SECTION**  
**5** Shown w/ 2X Buck  
 Inswing shown

**Note:**

1. Screws located 8" from each end of astragal plus four (3) more located @ 23", 37" & 48" down from the top of the astragal (5 screws total - countersink 3/16").

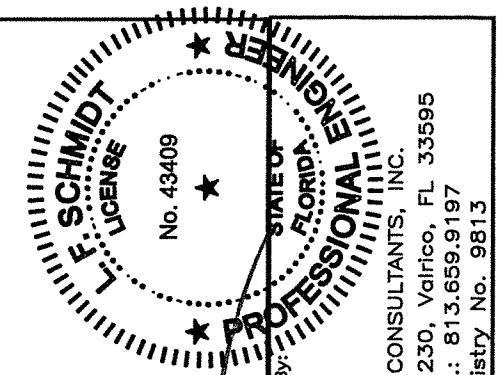

June 6, 2022  
 Documents Prepared By:  
 Lyndon F. Schmidt  
 P.E. No. 43409

*RW*  
 BUILDING CONSULTANTS, INC.  
 P.O. Box 230, Valrico, FL 33595  
 Phone No.: 813.659.9197  
 FBPE Registry No. 9813

PRODUCT: STEVES & SONS  
 FIBERGLASS DOOR  
 PART OR ASSEMBLY:  
 HORIZONTAL & VERTICAL  
 CROSS SECTIONS (2X BUCK)

NO.	DATE	BY

DATE: 4/26/22  
 SCALE: N.T.S.  
 DWG. BY: RW  
 CHK. BY: LFS  
 DRAWING NO.:  
 FL-41477.2  
 SHEET 5 of 10

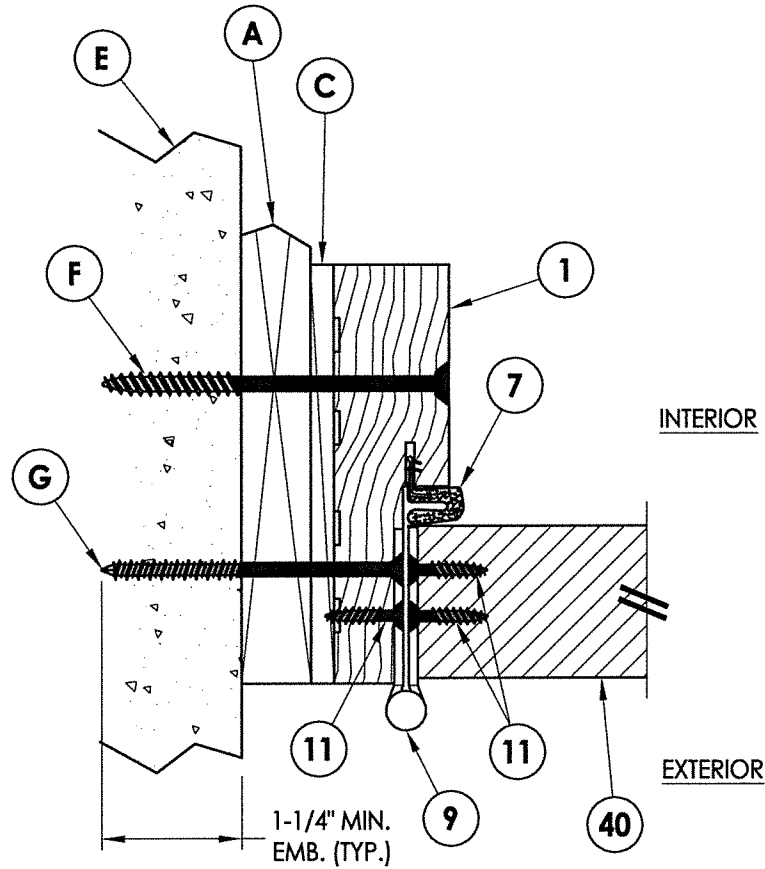

**1 HORIZONTAL CROSS SECTION**  
 6 Shown w/ 1X Buck  
 Outswing shown (Inswing similar)

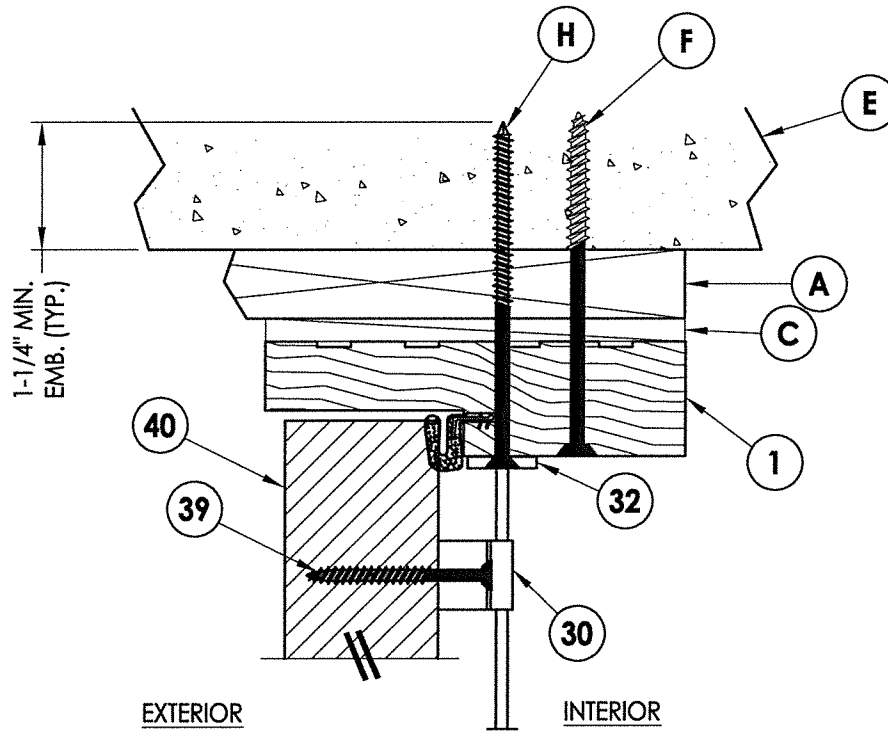

**2 VERTICAL CROSS SECTION**  
 6 Shown w/ 1X Buck  
 Outswing shown

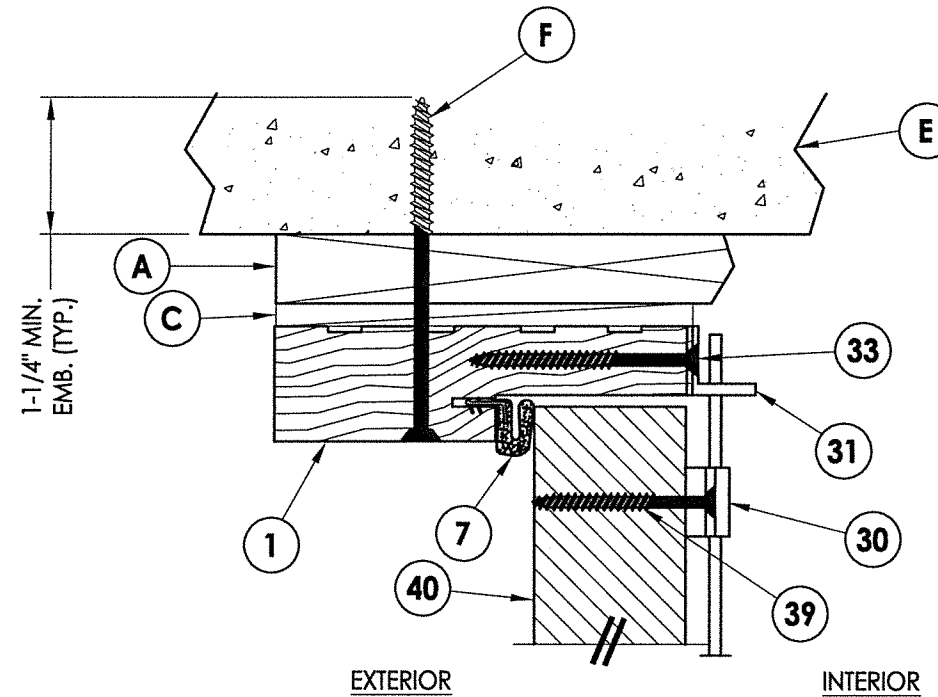

**3 VERTICAL CROSS SECTION**  
 6 Shown w/ 1X Buck  
 Inswing shown

June 6, 2022  
 Documents Prepared By:  
 Lyndon F. Schmidt  
 P.E. No. 43409

*RW* BUILDING CONSULTANTS, INC.  
 P.O. Box 230, Valrico, FL 33595  
 Phone No.: 813.659.9197  
 FBPE Registry No. 9813

<b>PRODUCT:</b>	STEVES & SONS FIBERGLASS DOOR	
<b>PART OR ASSEMBLY:</b>	HORIZONTAL & VERTICAL CROSS SECTIONS (1X BUCK)	
<b>NO.</b>	<b>DATE</b>	<b>BY</b>
<b>REVISIONS</b>		
DATE: 4/26/22		
SCALE: N.T.S.		
DWG. BY: RW		
CHK. BY: LFS		
DRAWING NO.: FL-41477.2		
SHEET 6 OF 10		

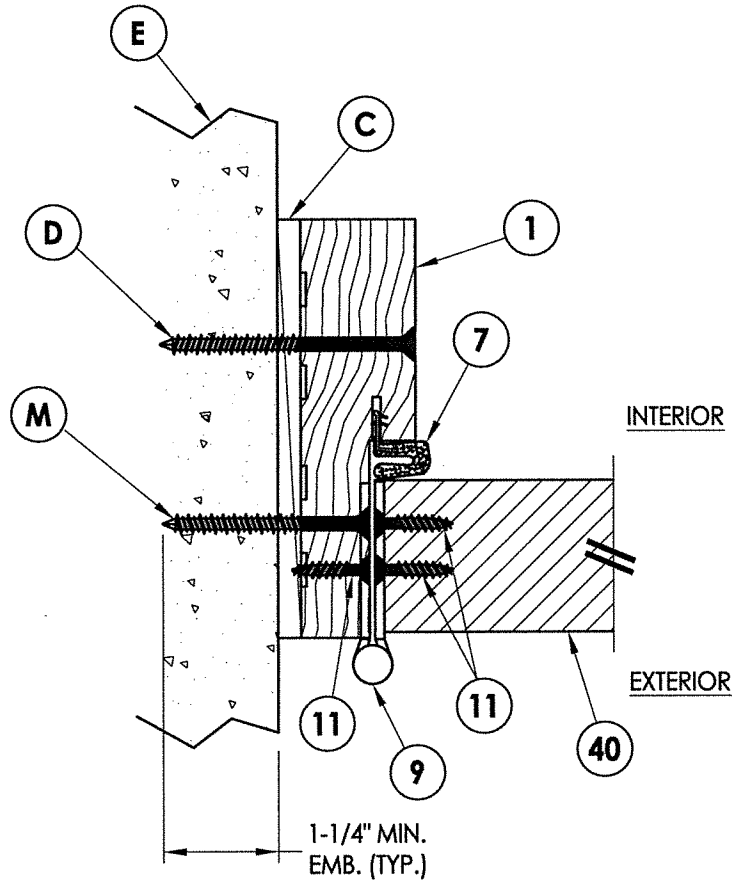

**1**  
**7** **HORIZONTAL CROSS SECTION**  
Shown Direct to Masonry  
Outswing shown (Inswing similar)

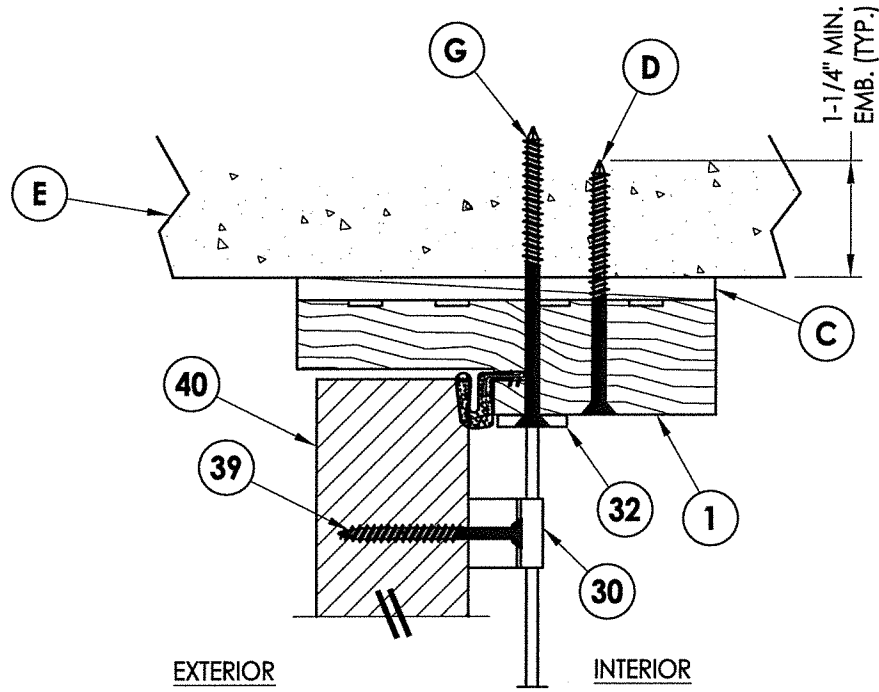

**2**  
**7** **VERTICAL CROSS SECTION**  
Shown Direct to Masonry  
Outswing shown

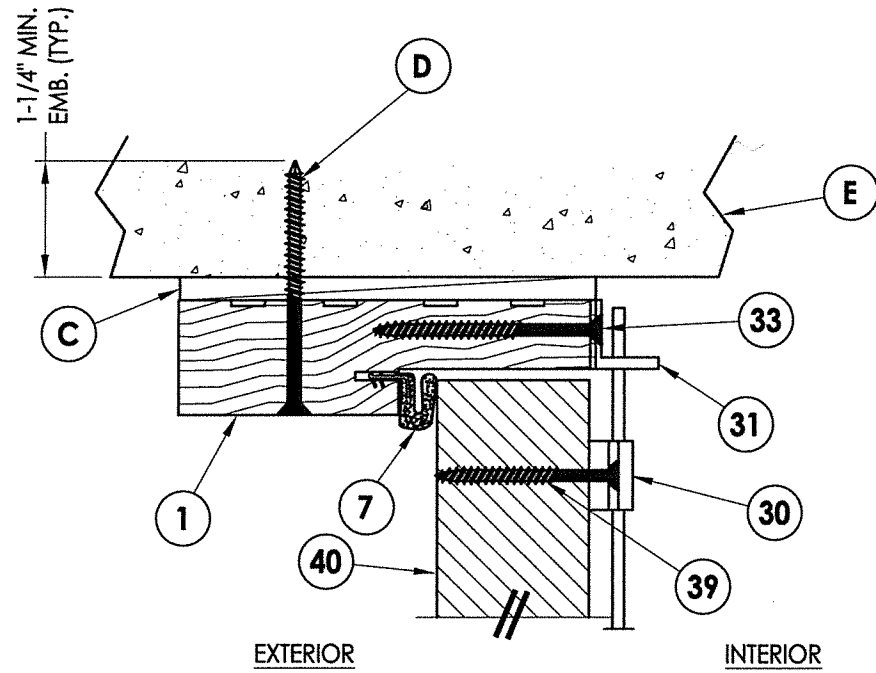

**3**  
**7** **VERTICAL CROSS SECTION**  
Shown Direct to Masonry  
Inswing shown

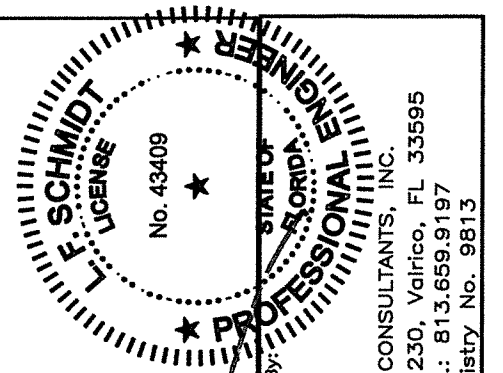

June 6, 2022  
Documents Prepared By:  
Lyndon F. Schmidt  
P.E. No. 43409

**RW** BUILDING CONSULTANTS, INC.  
P.O. Box 230, Vairico, FL 33595  
Phone No.: 813.659.9197  
FBPE Registry No. 9813

PRODUCT:  
STEVE'S & SONS  
FIBERGLASS DOOR

PART OR ASSEMBLY:  
HORIZONTAL & VERTICAL CROSS  
SECTIONS (DIRECT TO MASONRY)

NO.	DATE	BY	REVISIONS

DATE: 4/26/22  
SCALE: N.T.S.  
DWG. BY: RW  
CHK. BY: LFS  
DRAWING NO.:  
FL-41477.2  
SHEET 7 OF 10

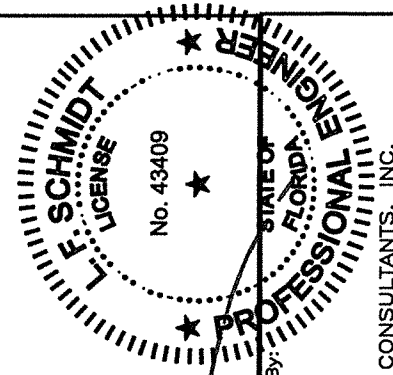
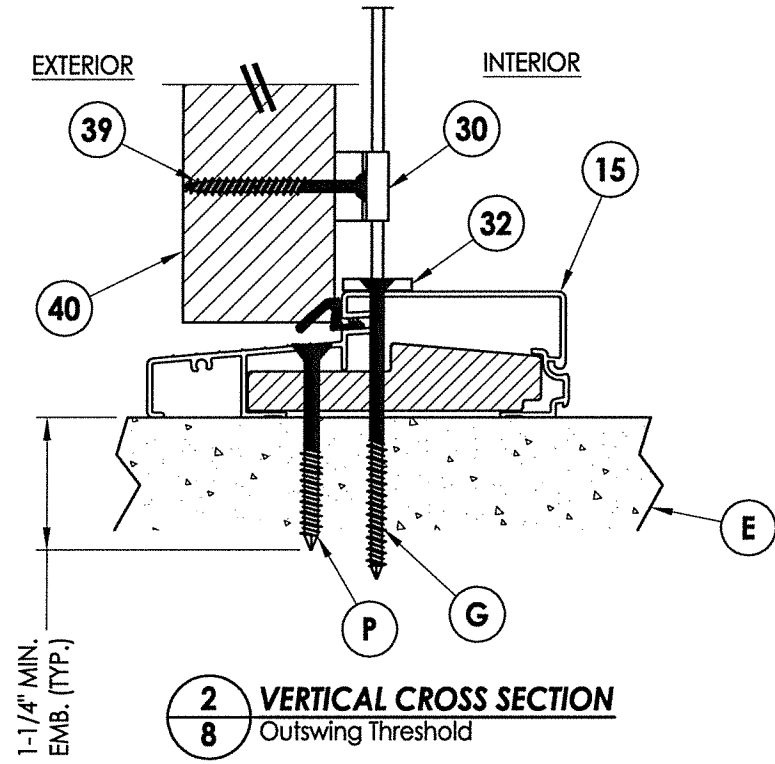
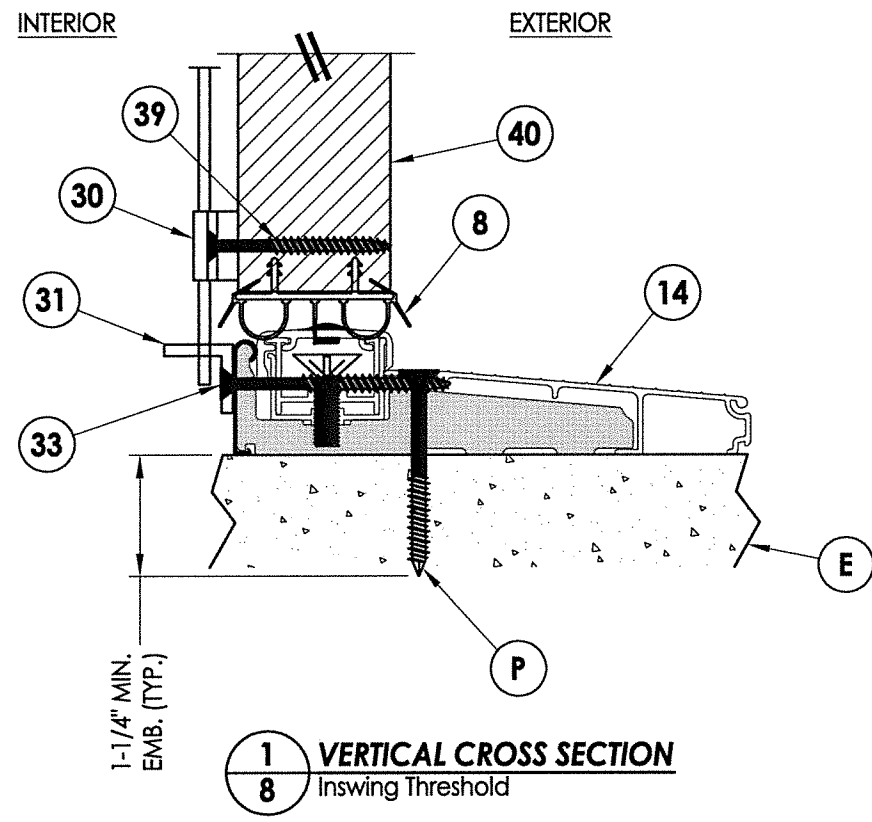

*LFS*

June 6, 2022

Documents Prepared By:  
Lyndon F. Schmidt  
P.E. No. 43409

*RW* BUILDING CONSULTANTS, INC.  
P.O. Box 230, Valrico, FL 33595  
Phone No.: 813.659.9197  
FBPE Registry No. 9813

PRODUCT: STEVES & SONS FIBERGLASS DOOR

PART OR ASSEMBLY: VERTICAL CROSS SECTIONS

NO.	DATE	BY	REVISIONS

DATE: 4/26/22

SCALE: N.T.S.

DWG. BY: RW

CHK. BY: LFS

DRAWING NO.: FL-41477.2

SHEET 8 OF 10



Z:\Clients\Steves and Sons - Permanent\VA - Florida Product Approvals\FL-41477 RELIANT SERIES\C - Drawings\FL-41477 (2020)\FL-41477.2.dwg

FRAME CORNERS ATTACHED w/ (3) 7/16"  
CROWN X 1-1/2" LONG 16 GA. STAPLES & (2)  
#7 X 1-5/8" DRYWALL SCREWS @ HEAD & SILL  
(TYP.)

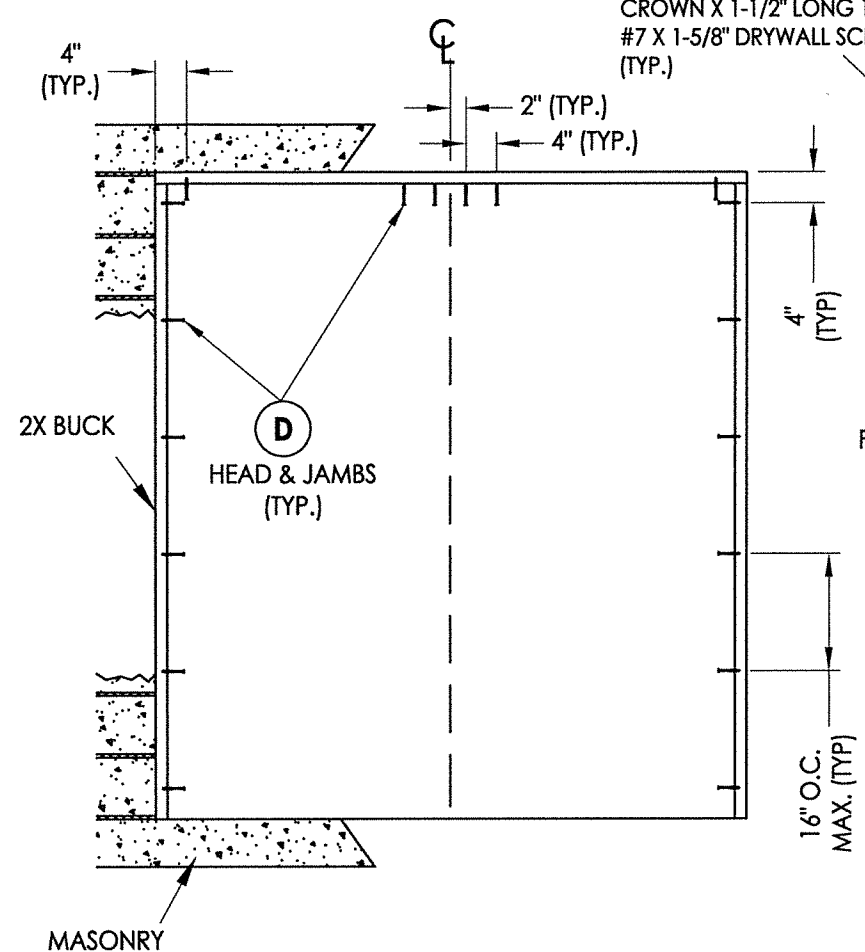

**2X BUCK ANCHORING**

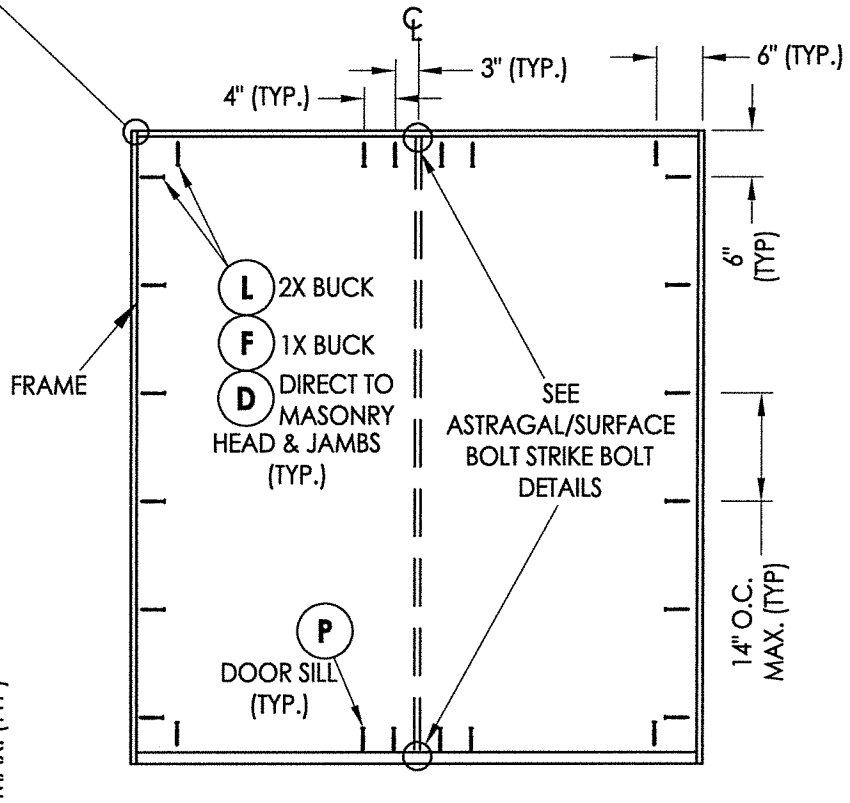

**FRAME ANCHORING**

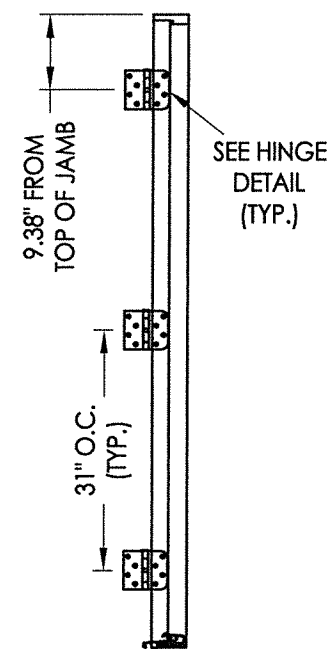

**HINGE JAMB**

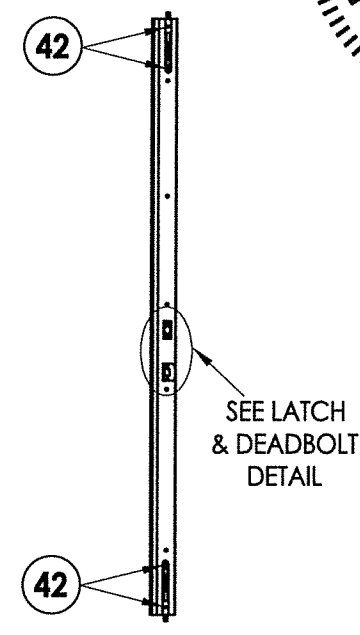

**COMPOSITE ASTRAGAL**  
7" STEEL FLIP LOCK FLUSHBOLT (5/16" Ø)  
@ EACH END OF ASTRAGAL

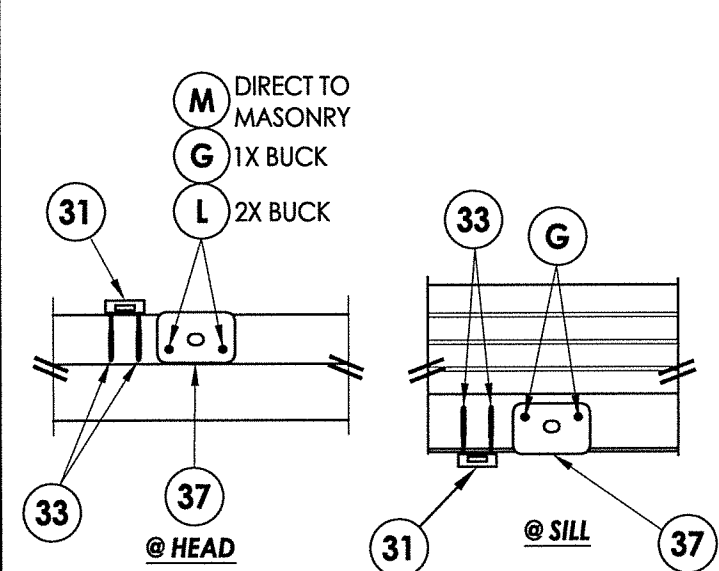

**ASTRAGAL/SURFACE BOLT STRIKE PLATE DETAILS**  
INSWING

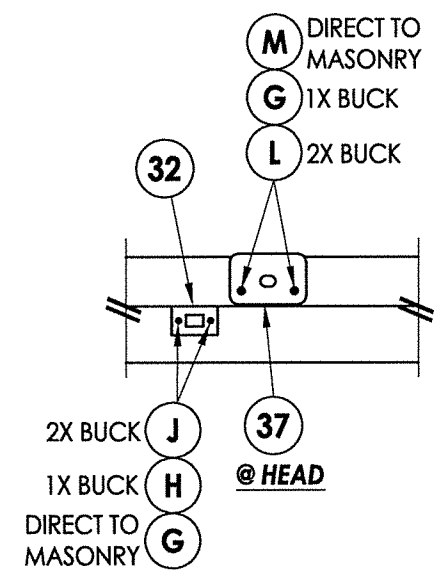

**ASTRAGAL/SURFACE BOLT STRIKE PLATE DETAILS**  
OUTSWING

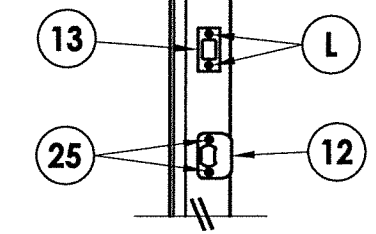
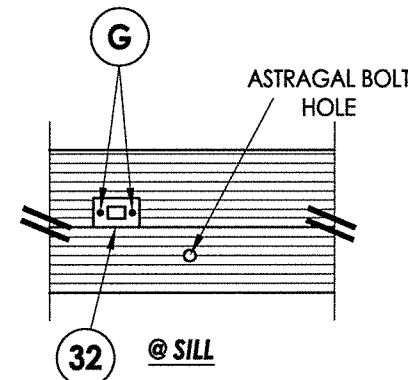

**LATCH & DEADBOLT DETAIL**

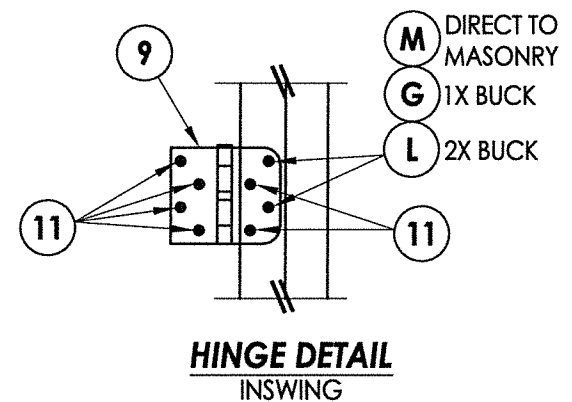

**HINGE DETAIL**  
INSWING

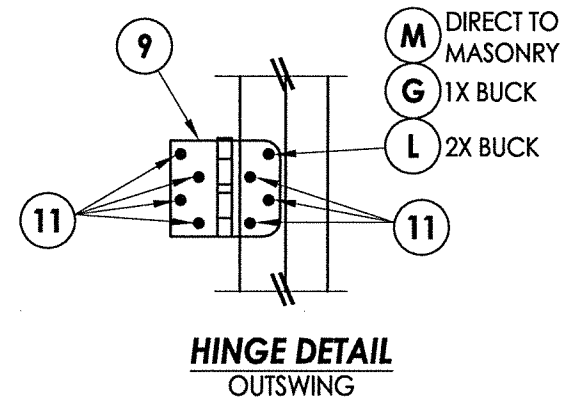

**HINGE DETAIL**  
OUTSWING

**HARDWARE DETAILS**

Professional Engineer  
 L. F. SCHMIDT  
 License No. 43409  
 State of Florida  
 June 6, 2022  
 Documents Prepared By:  
 Lyndon F. Schmidt  
 P.E. No. 43409  
 R.W.  
 BUILDING CONSULTANTS, INC.  
 P.O. Box 230, Valrico, FL 33595  
 Phone No.: 813.659.9197  
 FBPE Registry No. 9813

PRODUCT:	STEVES & SONS FIBERGLASS DOOR	
PART OR ASSEMBLY:	BUCK & FRAME ANCHORING & HARDWARE DETAILS	
NO.	DATE	BY
REVISIONS		
DATE:	4/26/22	
SCALE:	N.T.S.	
DWG. BY:	RW	
CHK. BY:	LFS	
DRAWING NO.:	FL-41477.2	
SHEET	9	OF 10

Z:\Clients\Stevens and Sons - Permanent\A - Florida Product Approvals\FL-41477 RELIANT SERIES\C - Drawings\FL-41477 (2020)\FL-41477.2.dwg

BILL OF MATERIALS		
ITEM #	DESCRIPTION	MATERIAL
A	1X BUCK (G >= 0.42)	WOOD
B	2X BUCK (G >= 0.42)	WOOD
C	1/4" MAX. SHIM SPACE	-
D	1/4" X 2-3/4" PFH DeWALT OR ITW CONCRETE SCREW	STEEL
E	MASONRY - 3,000 PSI MIN. CONCRETE CONFORMING TO ACI 301 OR HOLLOW BLOCK CONFORMING TO ASTM C90	CONCRETE
F	1/4" X 3-3/4" PFH DeWALT OR ITW CONCRETE SCREW	STEEL
G	3/16" X 3-1/4" PFH ITW CONCRETE SCREW	STEEL
H	3/16" X 3-3/4" PFH ITW CONCRETE SCREW	STEEL
J	#10 X 3" PFH WOOD SCREW	STEEL
L	#10 X 2-1/2" PFH WOOD SCREW (1.15" MIN. EMB.)	STEEL
M	3/16" X 2-1/4" PFH ITW CONCRETE SCREW	STEEL
P	1/4" X 2-1/4" PFH DeWALT OR ITW CONCRETE SCREW	STEEL
1	WOOD JAMB	WOOD
7	WEATHERSTRIP	FOAM
8	SWEEP	VINYL
9	4" X 4" HINGE	STEEL
11	#9 X 3/4" PFH WOOD SCREW	STEEL
12	LATCH STRIKE PLATE	STEEL
13	DEADBOLT STRIKE PLATE	STEEL
14	INSWING THRESHOLD	ALUM/COMP
15	OUTSWING THRESHOLD	ALUM/COMP
25	#8 X 2-1/2" PFH WOOD SCREW	STEEL
30	8" SURFACE BOLT (HAGER 275D)	STEEL
31	SURFACE BOLT GUIDE PLATE	STEEL
32	SURFACE BOLT STRIKE PLATE	STEEL
33	#10 X 2-1/2" PFH WOOD SCREW	STEEL
37	ASTRAGAL STRIKE PLATE	STEEL
38	ASTRAGAL (COMPOSITE)	COMP
39	#10 X 2" FH SMS	STEEL
40	DOOR PANEL	-
41	#7 X 1-5/8" DRYWALL SCREW	STEEL
42	#8 X 2-1/2" FH SMS	STEEL

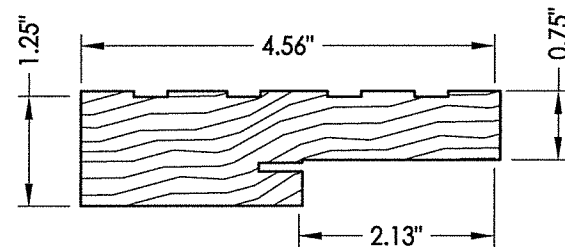

**1** WOOD JAMB  
FINGER JOINT PINE

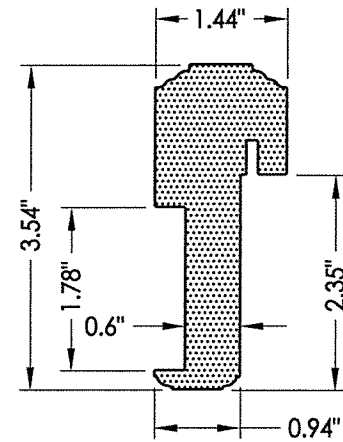

**38** COMPOSITE ASTRAGAL

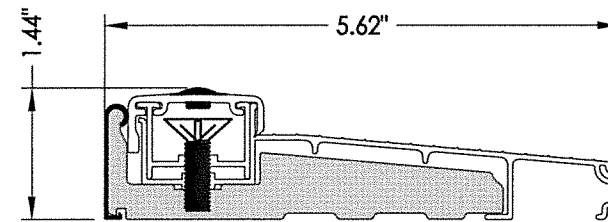

**14** INSWING THRESHOLD  
Columbia

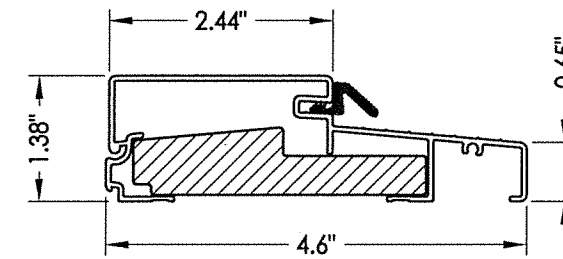

**15** OUTSWING THRESHOLD  
Columbia

**CONCRETE ANCHOR NOTES:**

- Concrete anchor locations at the corners may be adjusted to maintain the min. edge distance to mortar joints.
- Concrete anchor locations noted as "MAX. ON CENTER" must be adjusted to maintain the min. edge distance to mortar joints, additional concrete anchors may be required to ensure the "MAX. ON CENTER" dimension are not exceeded.
- Concrete anchor table:

ANCHOR TYPE	ANCHOR SIZE	MIN. EMBEDMENT	MIN. CLEARANCE TO MASONRY EDGE	MIN. CLEARANCE TO ADJACENT ANCHOR
ITW BUILDEX TAPCON®	3/16"	1-1/4"	3"	1-1/2"
	1/4"	1-1/4"	2"	4"
DeWALT ULTRA CON®	1/4"	1-1/4"	1"	4"

**WOOD SCREW INSTALLATION NOTES:**

- Maintain a minimum 5/8" edge distance, 1" end distance, & 1" o.c. spacing of wood screws to prevent the splitting of wood.

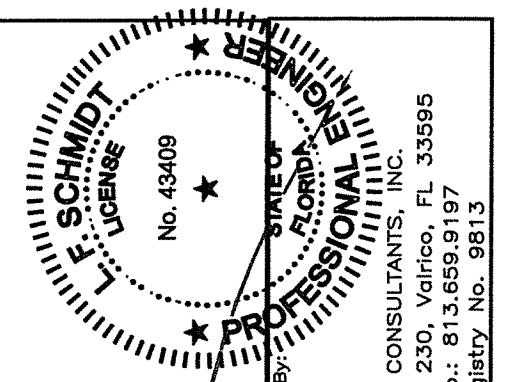

June 6, 2022  
 Documents Prepared By:  
 Lyndon F. Schmidt  
 P.E. No. 43409  
 R.W.  
 BUILDING CONSULTANTS, INC.  
 P.O. Box 230, Valrico, FL 33595  
 Phone No.: 813.659.9197  
 FBPE Registry No. 9813

PRODUCT: STEVES & SONS  
FIBERGLASS DOOR  
 PART OR ASSEMBLY: BILL OF MATERIALS & COMPONENTS

NO.	DATE	BY	REVISIONS

DATE: 4/26/22  
 SCALE: N.T.S.  
 DWG. BY: RW  
 CHK. BY: LFS  
 DRAWING NO.: FL-41477.2  
 SHEET 10 OF 10